

PAPER • OPEN ACCESS

Improving the technology of aluminothermic rail welding based on software simulation

To cite this article: M S Galay and A S Ilinykh 2021 *J. Phys.: Conf. Ser.* **1967** 012063

View the [article online](#) for updates and enhancements.

You may also like

- [Modern Methods of Rail Welding](#)
Nikolay A Kozyrev, Olga A Kozyreva, Aleksander A Usoltsev et al.
- [Control of the properties of metal alloys obtained by aluminothermy](#)
O N Komarov, S G Zhilin, V V Predein et al.
- [Influence of heat treatment modes on the formation of structure and physical and mechanical properties of cast blanks from the aluminothermic alloys](#)
A V Popov, V V Predein, S G Zhilin et al.



The Electrochemical Society
Advancing solid state & electrochemical science & technology

241st ECS Meeting

May 29 – June 2, 2022 Vancouver • BC • Canada

Extended abstract submission deadline: Dec 17, 2021

Connect. Engage. Champion. Empower. Accelerate.
Move science forward



Submit your abstract



Improving the technology of aluminothermic rail welding based on software simulation

M S Galay^{1*} and A S Ilinykh¹

¹Siberian Transport University, 191 Dusi Koval'chuk Street, Novosibirsk, 630049, Russia

E-mail: *galayms@mail.ru

Abstract. One of the modern methods of connecting railway rails when creating a continuous welded track is thermite welding. The gap between the rails, into which the metal is poured, is 25 mm. However, when repairing rails on the way, it may not be enough to eliminate the defective rail section. Therefore, an increase in the welding gap up to 50 mm is considered a promising direction in the development of thermite welding of rails. This study presents the results of modeling the process of rail welding by the thermite method using the NovaFlow& Solid CV software package. The purpose of the study was to assess the change in the length of the weld zone and heat-affected zone with an increase in the welding gap from 25 to 50 mm. The results of the simulation are thermograms reflecting the distribution of heat from the weld zone into the rails. These thermograms were used to determine the boundaries of the welded seam and the heat-affected zone. It was found that the use of a welding gap of 50 mm, instead of 25 mm, leads to the increase in the length of the welded seam by 1.3—1.6 times.

1. Introduction

On the railroad, thermite welding is used when welding rails. Thermite welding consists of two processes: the casting process and the rail welding itself. The casting process is as follows: a casting mold is installed at the ends of the rails (figure 1), then above the junction of two rails, a melting crucible is installed, into which a special powder is poured - thermite. Thermite is a mechanical mixture of iron oxides and aluminum powder. The source of oxygen in thermite is the oxide, and the source of heat is the metal that enters the mixture in pure form. Iron scale is used as oxides in thermite mixtures, and aluminum is used as combustible metals. Then the thermite is ignited and when it burns, an exchange reaction of oxygen takes place with the release of a significant amount of heat. The molten metal is poured from the crucible into the casting mold and fills the gap left between the ends of the rails, starting from the foot of the rails, where it enters through a special sprue channel. Gradually filling the gap and empty space between the rails and the walls of the mold, the metal causes melting of the rail walls in contact with the end surfaces, and, solidifying, forms a single whole with the rails - a welded joint. The slag flowing out of the crucible behind the metal flows down the chute, leaving only a thin layer above the metal [1, 2].



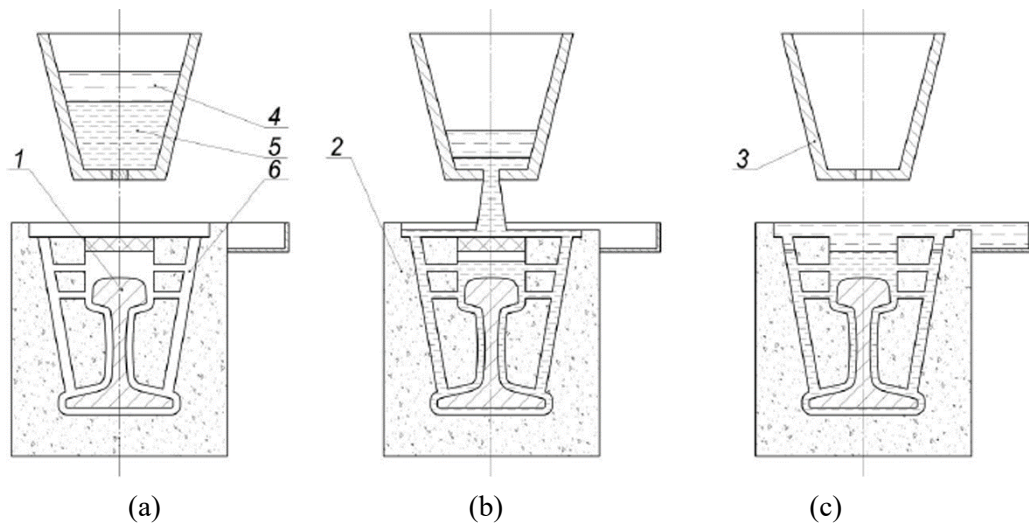

1- rail, 2 - mold, 3-crucible, 4 -molten slag, 5 - molten metal, 6 - sprue,
 (a) melting of the thermite mixture, (b) pouring the molten thermite mixture into the mold,
 (c) crystallization of the weld

Figure 1. Scheme of thermite welding of rails by the method of intermediate casting.

Today, when welding rails by the thermite method, casting molds with a standard technological gap of 25 mm are used between the rails to be welded. When repairing and restoring a continuous welded track, casting molds with a technological gap of 50 mm are used. It should be noted that most of the studies are devoted to the study of thermite welded joints obtained using casting molds with a standard technological gap of 25 mm [3-12], and the technology of producing rail welded joints using casting molds with a gap of 50 mm remains underexplored.

The purpose of the work is to determine the width of the weld and the heat-affected zone of the thermite welded rails joints obtained using a casting mold with a technological gap of 50 mm by computer simulation.

In modern mechanical engineering, a large number of computer programs are used that allow you to simulate technological processes, determine the optimal processing modes for product manufacturing and identify defects at the design stage. In the foundry industry, the most popular foundry simulation programs are Procast, SOLIDCast, NovaFlow& Solid CV, and PoligonSoft. Using these programs, the technologist can select rational casting parameters, while there is no need to carry out field experiments.

In our study, we used the NovaFlow& Solid CV program to simulate the casting process in the production of thermite welded rail joints. Determination of the width of the weld and the heat-affected zone is a time consuming task associated with the complexity of preparing macro sections. Earlier in [13-17], when studying the hardness of the weld and heat-affected zones, it was found that the width of the weld along the rolling surface when using a mold with a technological gap of 25 mm can reach from 50-70 mm. It is known that the hardness of the weld is lower than the hardness of the rail, therefore, on the rolling surface of the rail in the weld area of thermite welded joints can develop defects such as crushing and wear. Therefore, the larger the width of the weld, the higher the probability of the above mentioned defects.

2. Modeling

For modeling in the NovaFlow& Solid CV program, it is necessary to build 3D models of all objects involved in the production of thermite welded rail joints: rail, weld and mold. In the computer-aided three-dimensional design system KOMPAS-3D, two models of a rail 500 mm long each one and a casting mold were built (figure 2). The dimensions of the rail model profile correspond to [18]. The

mold model is built according to [19]. Also, a model of a welded seam with a technological gap of 50 mm was designed (figure 3).

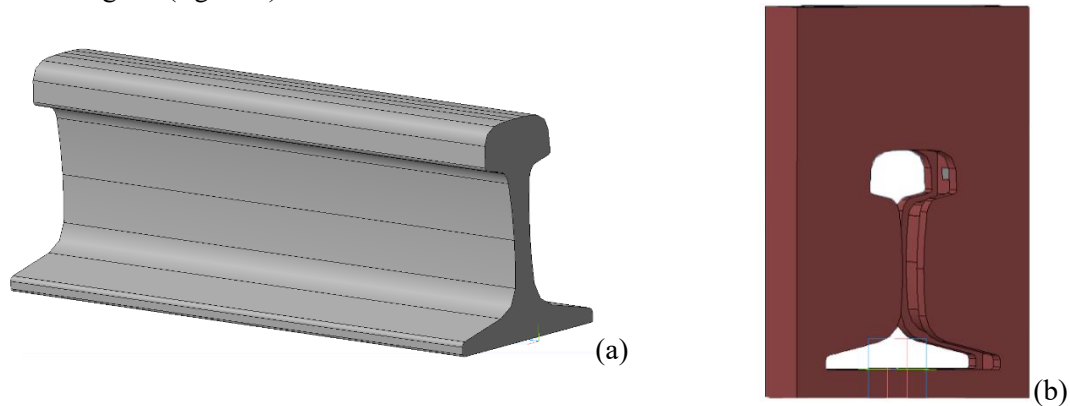

Figure 2. Models: (a) rail R65, (b) mold.

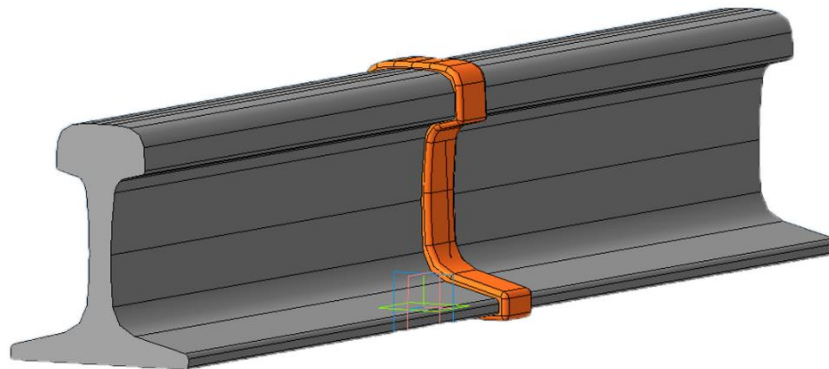

Figure 3. Model of the weld seam and rails in the assembly.

The designed models of rails of 500 mm, a weld seam and a mold with a technological gap of 50 mm were connected into an assembly. Then the assembly was loaded into the NovaFlow& Solid CV software package (figure 4).

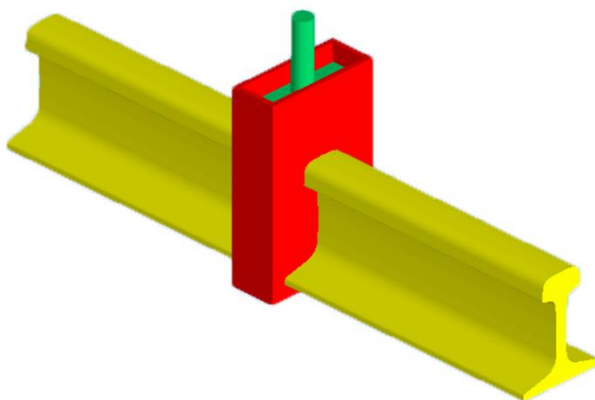

Figure 4. Assembly converted with NovaFlow& Solid CV.

For each item in the assembly, a material was selected from the material database. A steel grade with a carbon content of 0.7-0.8% was chosen for the rail, quartz sand for the casting mold, and a material with a carbon content of 0.5-0.6% for the weld seam. In addition, according to the technological process of manufacturing thermite welds, the operation of preheating the rails before welding is carried out, therefore the initial temperature of the rails was set at 8500°C in the program. The temperature of the poured metal was 2300°C. The ambient temperature, in our case the air

temperature at which welding is carried out on the way, was set at 20 °C. After entering the initial conditions, the gating point and temperature sensors were set (figure 5). The sensors were installed along the length of the rail welded joint near the rolling surface of the rail.

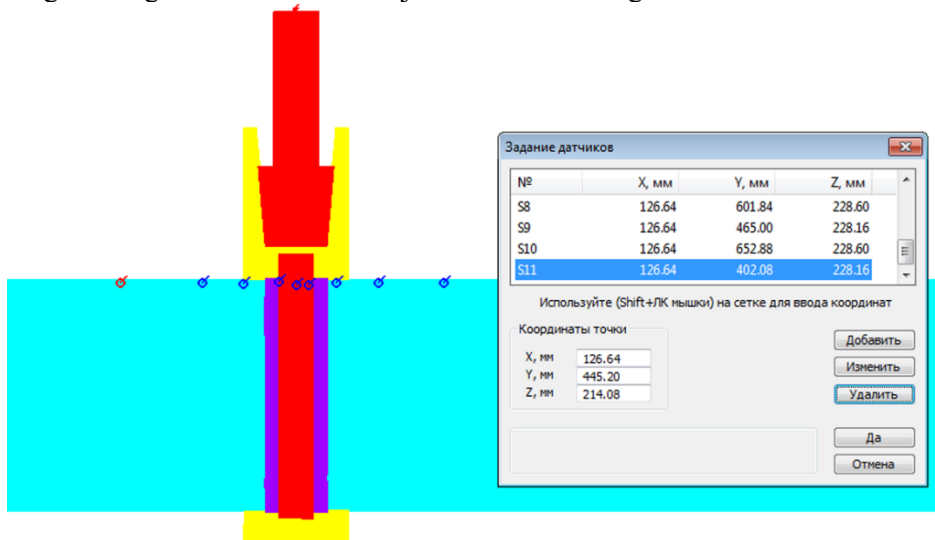

Figure 5. Installation diagram of temperature sensors.

3. Results

The simulation results are presented in the form of temperature fields (figure 6) that appear in the rails during their welding. The temperature field can be used to judge the size of the heat-affected zone and the size of the weld, and temperature sensors make it possible to determine the temperature values in the weld and the heat-affected zone at different distances from the fusion boundary.

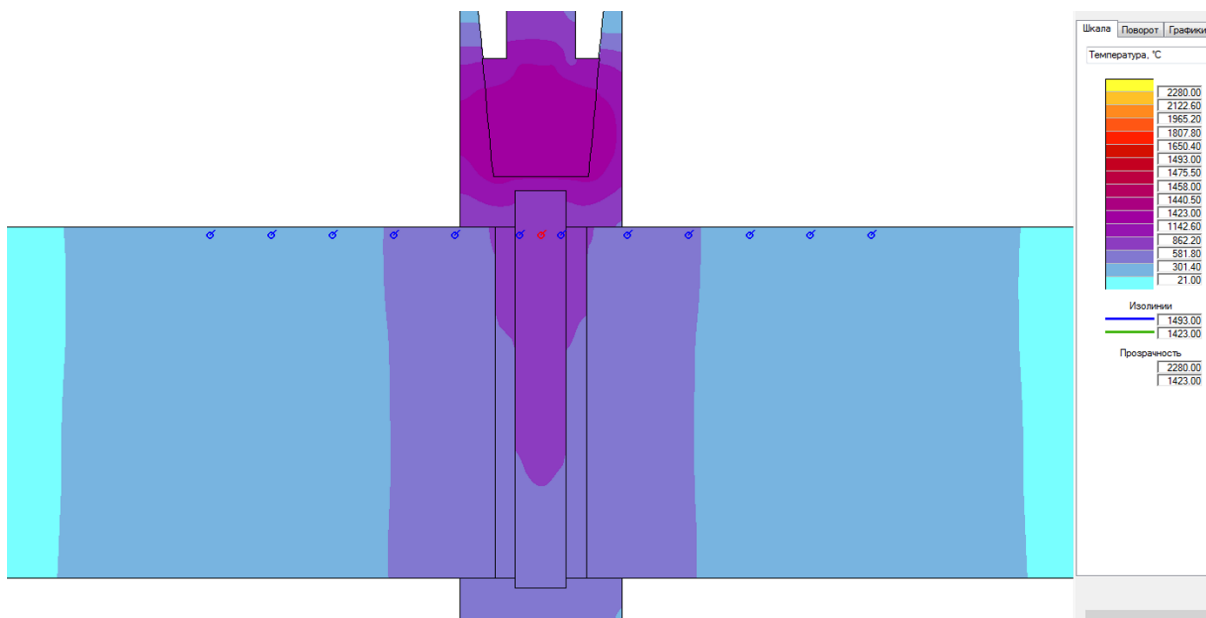

Figure 6. Temperature field in the zone of the weld seam and seated rails.

In order to determine the width of the weld and the heat-affected zone, we will use the data on the structure of the welded joint of low-carbon steel, presented in figure 7 [20].

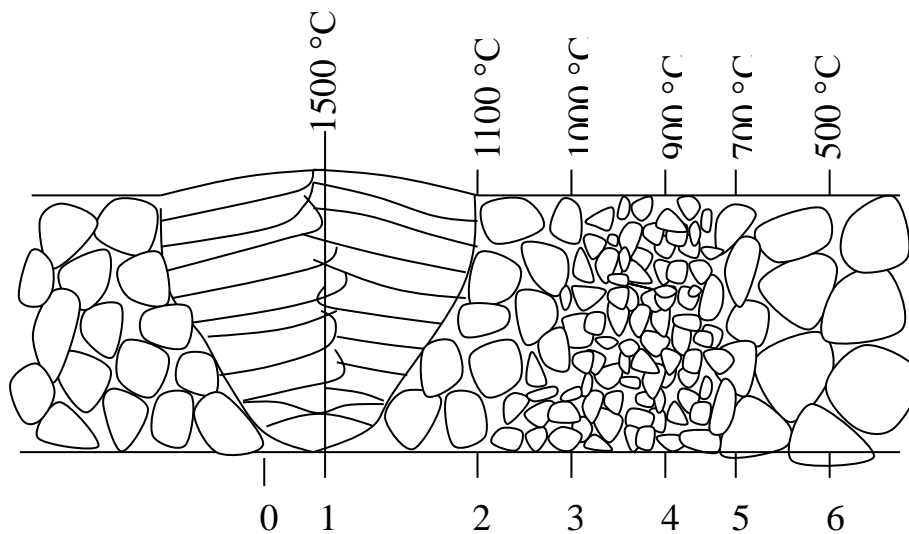

Figure 7. The structure of the welded joint of low-carbon steel:
1 - weld seam, 2 - 6 - heat-affected zone.

For low-carbon steel with a carbon content of up to 0.3%, the melting temperature is approximately 1100 °C, therefore, in figure 7; the weld zone is limited to this temperature. In our case, the carbon in the weld is 0.5 - 0.6%. The melting temperature of steel with such carbon content is about 1480 °C. In figure 6, this temperature corresponds to the area of dark purple colour. The length of this area is about 80-90 mm, which corresponds to the size of the weld zone.

The width of the heat-affected zone is determined by the heating temperature of the rail being welded. It is known that the heat-affected zone is the portion of the base metal adjacent to the seam, in which structural changes have occurred as a result of heating. As can be seen from Figure 7, for low-carbon steel, structural changes occurred up to a temperature of 500 °C, this will be the heat-affected zone. In our case, for steel with a carbon content of 0.7-0.8%, the heat-affected zone should be limited to a temperature of 600 - 650 °C. The distance from the point of the vertical axis of the weld seam (red point in figure 6) to the point 600 °C is 120 -140 mm. Consequently, the length of the heat-affected zone is about 80 - 95 mm.

4. Summary

Thus, the study made it possible to determine the area of the weld seam and the heat-affected zone of the thermite welded rail joint obtained using casting molds with a technological gap of 50 mm. It was found that the use of a mold with a technological gap of 50 mm, instead of a mold with a gap of 25 mm, leads to an increase in the length of the weld zone by 30 - 60%. The simulation results can be used in the development of methods for monitoring thermite welded joints of rails by non-destructive testing methods, as well as in the development of technologies for strengthening the welded joints of rails.

5. References

- [1] TU 0921-337-01124323-2016 Railway rails welded in a thermite way Technical specifications (Moscow, 2016) (in Russian)
- [2] TI 0921-002-59033294-2017 Technological instruction for thermite welding of rails by the method of intermediate casting with a technological gap of the connected rails with a width of 24 to 26 mm according to the technology (Moscow, 2017) (in Russian)
- [3] Yamamoto R , Terashita Y, Tatsumi M, Itoh H and Umenai K 2016 Investigation of Cause and Prevention Measures against Surface Defects on Thermit Welds *Quarterly Report of RTRI* **2** (57) 112-7
- [4] Costea D M, Găman M N and Dumitru G 2014 The weld aluminothermic optimization of rail track by microalloyed *Bulletin of the Transilvania University of Braşov CIBv* **7** 56 285 – 8

- [5] Brânzei M and Coman T 2012 Structure Improvement of Aluminothermic Welding Joints by Using Modifiers *International Journal of Chemical, Molecular, Nuclear, Materials and Metallurgical Engineering* **6** (8) 745-8
- [6] Saarna M and Laansoo A 2004 Rail and rail weld testing *Proc. 4th International DAAAM Conference "Industrial engineering – innovation as competitive edge for SME"* (Tallinn, Estonia, 29-30 April 2004) pp. 217-9
- [7] Mouallif Z, Radi B and Mouallif I 2015 The Thermomechanical Modeling of Aluminothermic Welds Affected by Different Defects *International Journal of Engineering Research and Development* **11** 44-8
- [8] Sidki F, Mouallif I, Mouallif Z and Benali A 2012 Finite element modeling of the aluminothermic welding with internal defects and experimental analysis, *Proc. International Conference on Structural Nonlinear Dynamics and Diagnosis CSNDD'2012 (MATEC Web of Conferences1)* (Marrakech, Maroc, 2012) DOI: 10.1051/mateconf/2012010000
- [9] Usoltsev A A, Shevchenko R A, Kozyrev N A, Kriukov R E and P E Shishkin 2017 Analysis of rail welding methods for mine rail access with the use of modern technologies *IOP Conference Series: Earth and Environmental Science* **84** 1–7 (012025) DOI: 10.1088/1755-1315/84/1/012025
- [10] Weiss S, Riehl I, Hantusch J and Gross U 2018 Numerical investigation on the crucible discharge of steel and slag during the aluminothermic welding process *Archives of Metallurgy and Materials* **63** (1) 173-80
- [11] Josefson B L, Bisschop R, Messaadi M and Hantusch J 2020 Residual stresses in thermite welded rails: significance of additional forging *Welding in the World* **64** (7) 1195-1212 DOI: 10.1007/s40194-020-00912-4
- [12] Alves L H D, Tepedino T C, Masoumi M, Tressia G, Goldenstein H 2020 Metallurgical and tribological aspects for squat formation in the aluminothermic weld HAZ, edges of rails welded using aluminothermy *Industrial Lubrication and Tribology* **72** (9) 1123-31
- [13] Tikhomirova L B, Ilinykh A S, Galay M S and Sidorov Je S 2016 The effect of normalization on the structure and mechanical properties of rails aluminotermite welded joints *Obrabotkametallov (tekhnologiya, oborudovanie, instrumenty) – Metal Working and Material Science* **1(70)** 60-6 DOI: 10.17212/1994-6309-2016-1-60-66
- [14] Kargin V A, Tikhomirova L B, Galay M S and Kuznetsova Y S 2015 Improving service properties of welded joints produced by aluminothermic welding *Welding International* **29** (2) 155-7
- [15] Galay M and Sidorov E 2018 Increasing the operational stability of running surfaces of aluminothermic welded rail joints by hot grinding *Proc.10thInternational Scientific and Technical Conference "Polytransport Systems"*(MATEC Web of Conferences) DOI: 10.1051/mateconf/201821601004
- [16] Ilinykh A S, Galay M S and Sidorov E S 2017 Investigation of welded rail joints after machining at different post-weld temperature *Obrabotka metallov (tekhnologiya, oborudovanie, instrumenty) – Metal Working and Material Science* **3** (76) 28–34 DOI:10.17212/1994-6309-2017-3-28-34
- [17] Manakov A L, Abramov A D, Ilinykh A S, Galay M S and Sidorov J S 2018 Improvement of aluminothermic welding on the basis of the experimentally-theoretical research of welding seam cooling process *Journal of Physics Conference Series* 1050(1):012051 DOI:10.1088/1742-6596/1050/1/012051
- [18] GOST 8161–75 Railway rails of the R65 type Design and dimensions (Moscow, 1977) (in Russian)
- [19] TU 159000-001-72253988-2009 Form for aluminothermic welding Technical specifications (Moscow, 2009) (in Russian)
- [20] Zorin N E and Zorin E E 2018 *Materialovedenie svarki Svarka plavleniem* [Materials science of welding. Fusion welding] (St Petersburg, Lan' Publ) p 164